

# Motor Purge & Pressurisation System D818

Purge flow rates up to 1,500 NI/min (53 SCFM)



## Features

- **Ambient temperature range:** Certified for use from -20°C to +55°C (-4°F to +131°F)
- **User Selectable Settings :**
  - 2 user selectable purge flow rates (1,000/1,500 NI/min) (35/53 SCFM)
  - 1-99 minute purge time (-0/+3 seconds tolerance). Suits a wide variety of machine frames sizes
- **Clear Visual Status Indication :** Local indicators for "Alarm/Pressurized" and "Purging".
- **Continuous Operation through Closed Loop Automatic Pressurization System (CLAPS) :** Eliminates spurious trips on start-up or load change.
- **316L Stainless Steel enclosure & fittings :** Excellent resistance to corrosion for harsh environments.
- **Full Compliance with Standards -** Direct purge flow measurement at Relief Valve exhaust orifice.
- **Global Approvals -** IECEx; ATEX; INMETRO; EAC

## Operation

The Motor Purging and Pressurization control system has been designed for use on large electrical machines located in a hazardous location.

The system delivers a high purge rate for a given duration (as defined by machine designer and Notified Body) prior to start-up, to purge any potentially explosive gases from the machine. After purge, the system automatically switches to leakage compensation mode for normal operation. Expo's Closed Loop Automatic Pressurization System (CLAPS) automatically compensate for pressure variations in the machine during start-up or through temperature variations during operation. The system enables the machine to continuously operate at a set over-pressure, saving considerable time during test and commissioning, simplifying normal operations.

## System Components

The system comprises the Control Unit (CU) and the Relief Valve (RLV). The Control Unit contains the pneumatic logic to monitor and control air flow, pressure and purge timing, and provides the system outputs.

The RLV measures purge flow at the outlet and provides over-pressure protection for the machine through a patented magnetically - set exhaust valve with integrated spark arrestor.

## Explosion Protection

Hazardous Area classification:

IECEX, INMETRO Zone 1, Group IIC T4 Gb

IECEX, IN METRO Zone 21, Group IIIC T100°C Db

ATEX Category 2 G, Zone 1, Group IIC T4 Gb

ATEX Category 2 D, Zone 21, Group IIIC T100°C Db

Ambient temperature: -20°C to +55°C (-4°F to +131°F)

## System Data D818

Control Unit

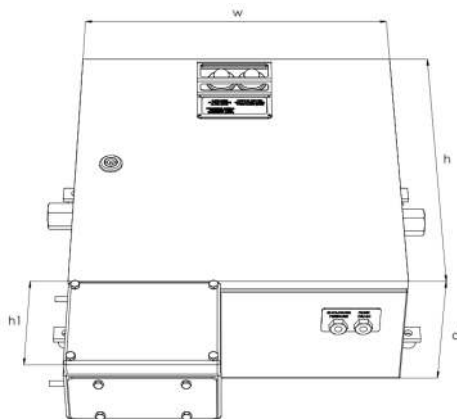

Relief Valve

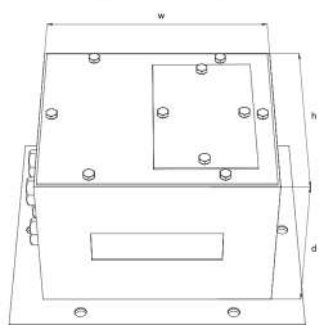

Dimensions	CU	RLV
Width w	400mm (15.7")	230mm (9")
Height h	400mm (15.7")	200mm (8")
Height h1	184mm (7")	N/A
Depth d	160mm (6.3")	134mm (5.3")
Weight	16kg (35lbs)	4kg (8.8lbs)

### Enclosure & Mounting:

Housing & external process connections 316L stainless steel.

Wall mounting lugs provided for fitting to machine.

### Process Connections:

Purge inlet: 1/2" NPT (F), recommended supply pipe: 1" I.D. min.

Purge outlet to machine: 1" NPT (F).

Reference point & signals: 1/8" NPT (F).

Purge gas: Clean Dry Air or Inert Gas.

Supply pressure: 4-8 barg (58-116 psi)

## Technical Specifications D818

**Order code: D818MOTORSYS-E**

**Description: 3XLC/ss/ET/OV/PA/PC/D818**

Purge flow rate: 1,000-1,500 NI/min (35-53 SCFM)

Leakage compensation: Up to 500 NI/min (18 SCFM)

### Common Data

Intrinsically safe Electronic Timer, range 1-99 mins. battery powered.

Option to use Electro Pneumatic Power Supply (EPPS)

System outputs are volt-free contact closures terminated in Exe Junction Box, with:

Power= 250 Vac 4 Amp (AC15) DPNO Ex d IIC T6

Alarm = 250 Vac 4 Amp (AC15) SPCO Ex d IIC T6

Intermediate Pressure/Pre-alarm = 250 Vac 4 Amp (AC15) SPCO Ex d IIC T6

Minimum pressure sensor default 1.5 mbarg (0.6"wc)

Range: 0.5 to 5 mbarg (0.2 to 2"wc)

Intermediate sensor/pre-alarm default 5 mbarg (2"wc)

Range: 2 to 10 mbarg (0.8 to 4"wc)

CLAPS sensor default 10 mbarg (4"wc). Range: 5.0 mbarg to 15 mbarg (2"wc to 6"wc)

Relief Valve Lift-Off pressure: default 30mbarg (12"wc)

Minimum: 20mbarg (8"wc), Maximum: 50mbarg (20"wc)

### Certification/Approvals:

IECEX Zone 1 Ex [pxb] ia IIC T4Gb

IECEX Zone 21 Ex [pxb] ia IIIC T100°C Db

ATEX II 2(2) G Ex [pxb] ia IIC T4 Gb

ATEX 112(2),0 Ex [pxb] ia IIIC T100°C Db

INMETRO/TUV Zone 1 Ex [pxb] ia IIC T4 Gb

INMETRO/TUV Zone 21 Ex [pxb] ia IIIC T100°C Db

EAC EAC: RU C-GB.AE61.B

Option: System purge in progress output kit, order code: KMP-1SPO-009